

Hiroshi Tsunoda  
Design Studio



OMIYAGE  
to go

An aerial photograph of Barcelona, Spain, taken during the golden hour of sunset. The city's characteristic grid pattern is clearly visible, with wide, tree-lined boulevards cutting through a dense urban fabric. In the center of the image, the Sagrada Família is the focal point, its intricate Gothic Revival architecture illuminated by the warm, low-angle light. Several construction cranes are visible around the cathedral, indicating ongoing work. The sky is a soft gradient of orange and grey, and the overall atmosphere is serene and majestic.

# BARCELONA

A group of five young women are sitting on a stone ledge overlooking a city. They are dressed in casual summer attire, including t-shirts, shorts, and hats. One woman in the center is holding a selfie stick with a camera attached, and they all appear to be smiling and posing for a photo. The background shows a cityscape with buildings and a clear sky.

The city welcomes the

55%

of the **Japanese**  
tourism in Spain



Over 300.000  
visit the city **every year**



There is an **increasement**

2017

361.013

A group of tourists, including men and women of various ages, are gathered in a historic city street. Many are holding cameras or binoculars, suggesting they are sightseeing. The background features ornate stone arches and a shop with a sign that reads "Salon de Thé". The overall atmosphere is one of a busy, tourist-friendly urban environment.

*Couple days to* **enjoy**  
and **visit** the city



The need to **buy** the  
**souvenirs** to bring to Japan



**Hundred** of stores and  
markets to buy **local products**

A close-up photograph of a person's hand wearing a watch and a brown jacket. The watch has a white face with black markings and a red strap. The background is blurred, showing a person's face in profile. The text "Not enough time to go shopping" is overlaid in white, with "enough" and "time" in bold.

Not **enough**  
**time** to go  
shopping

A photograph of a person in a blue polo shirt handing a cardboard box to another person. The person in blue is on the right, and their hands are visible holding the box. The other person's hands are on the left, also holding the box. In the background, there are several stacked cardboard boxes. The text "Our proposal" is overlaid in the center of the image, enclosed in a white rectangular border. The word "Our" is in a cursive font, and "proposal" is in a bold, sans-serif font.

*Our* **proposal**

A hand holding a smartphone, with a blurred background of bokeh lights. The text 'OMIYAGE to go' is overlaid in white, enclosed in a white L-shaped frame.

OMIYAGE  
to go

A photograph of three people outdoors, all focused on their mobile devices. In the foreground, a woman on the left with a yellow scarf uses a smartphone. In the center, a woman with a colorful plaid scarf uses a smartphone. In the background, a man with glasses uses a red tablet. The scene is set against a grey wall with a railing.

Buy from your  
**smartphone** and **tablet**

**While** you are  
on the **bus**

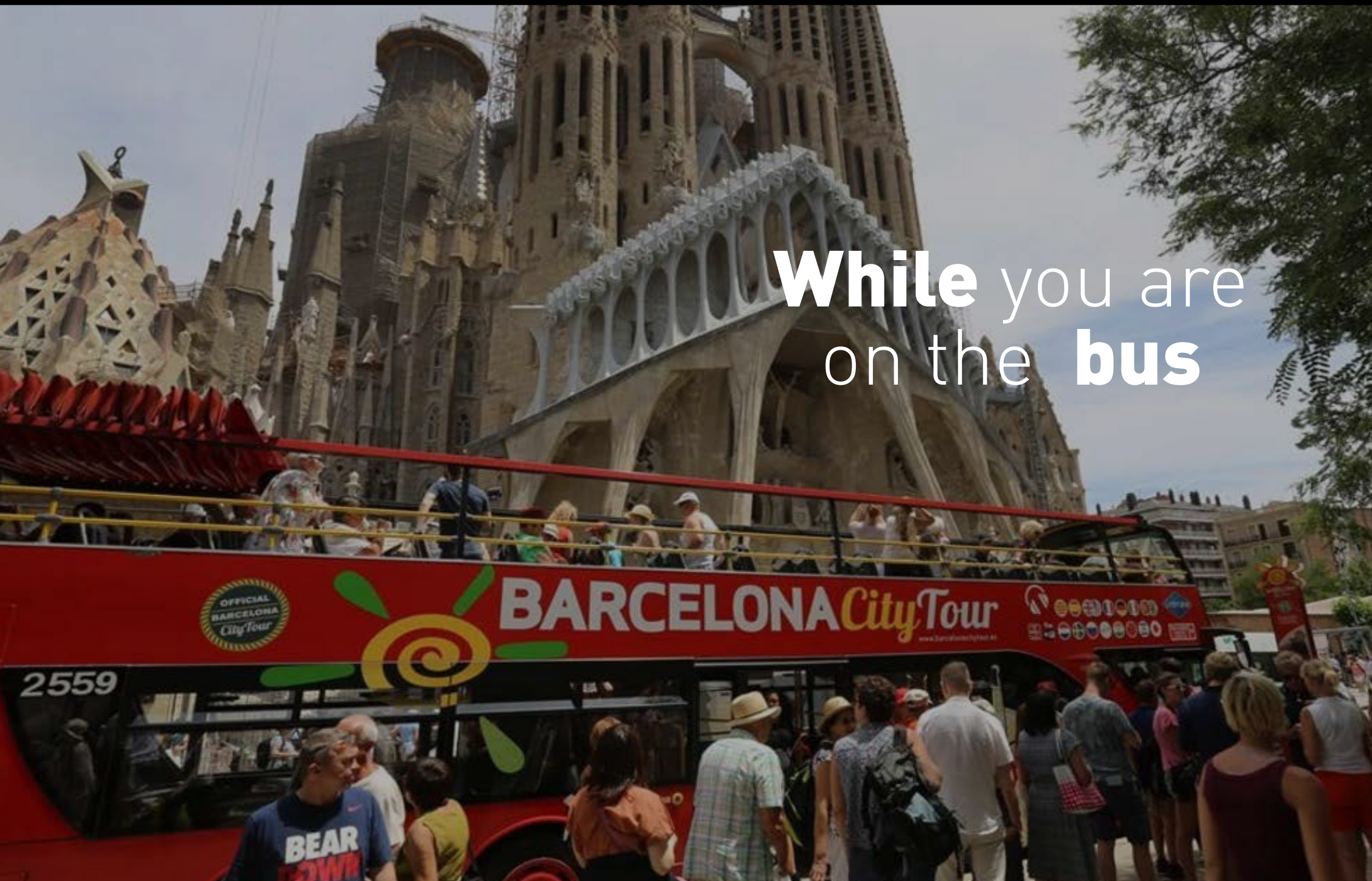

# Waiting in line





All the  
**products** on  
the **same site**



Make your  
**order**



**Choose** the  
**products** to put  
inside

# Three weight options

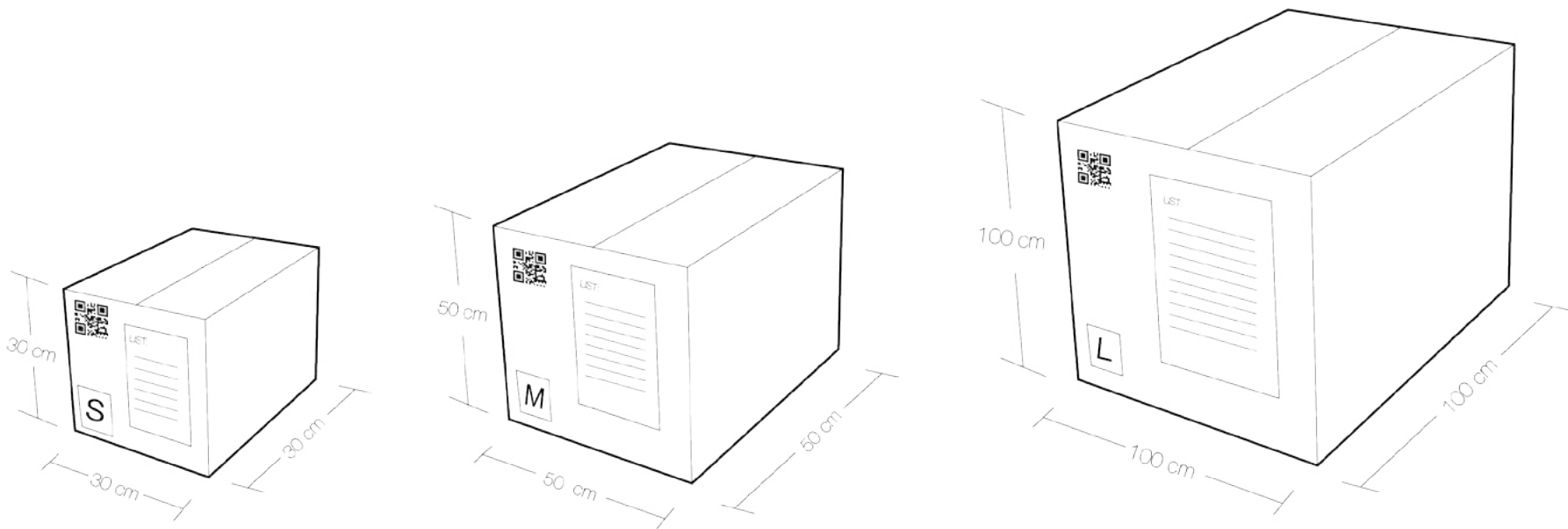

A gift basket filled with various lemon-themed products. The items include a box of Meyer Lemon Poppy Seed Quick Bread, a clear container of Spring Pops lollipops, a box of lemon candies, a jar of Fiona's Sherbet Lemons, and several small packets of lemon-flavored candies. The products are arranged in a cardboard box with yellow and green decorative paper. A large white text overlay is centered over the basket.

Or the possibility  
to buy a **pack**  
**already made**

# Pick up service

Glovo!

UBER EATS

unplis



deliveroo

A photograph of a hotel reception desk. A male employee in a grey uniform is handing a white card to a smiling couple. The woman has blonde hair and is wearing a dark blazer over a white shirt. The man is wearing a dark sweater over a light blue shirt. They are all smiling and looking at each other. The background is a blurred hotel lobby with warm lighting.

**Receive** it in  
the **hotel**

A person is walking through a crowded public space, carrying a large number of shopping bags and a cardboard box. The bags are in various colors, including orange, green, blue, and purple. The person is wearing a dark long-sleeved shirt and dark pants. The background shows other people walking, some blurred, suggesting a busy environment like a shopping mall or a busy street. The text "Do not carry more packages" is overlaid on the image in white, bold, sans-serif font.

Do **not** carry  
more packages



We help you to **save**  
**your time** for you to  
**enjoy** the **city**

# Hiroshi Tsunoda Design Studio

Hiroshi Tsunoda (Hiroshi Tsunoda Design Studio) holds the exclusive sole right on development and final production of the design that is presented in this document. Ownership of rights derived from intellectual and industrial property for the creations that are object of the present document exclusively belongs to Hiroshi Tsunoda (Hiroshi Tsunoda Design Studio), NIF X4055144-Z. Thus, Hiroshi Tsunoda (Hiroshi Tsunoda Design Studio) is the sole holder of the rights that correspond as author of the products that are object of the present document, the same in accordance to art. 2 of the Intellectual Property Law, Law 22/1987, dated November 11 on Intellectual Property, which includes ownership of the rights that are recognized in the Second Title of the same Law. Non-compliance of the above-mentioned conditions will be subject to an action at law before the Courts and Tribunals of the province of Barcelona, Spain.